

LICENSING SUB-COMMITTEE

Date: Friday 24 November 2017
Time: 10.00 am
Venue: Bad Homburg Room, Civic Centre, Paris Street, Exeter

Members are invited to attend the above meeting to consider the items of business.

If you have an enquiry regarding any items on this agenda, please contact Mark Devin, Democratic Services Officer (Committees) on 01392 265477 or email Mark.Devin@exeter.gov.uk

Entry to the Civic Centre can be gained through the Customer Services Centre, Paris Street.

Membership -
Councillors Brimble, Newby and Owen

Agenda

Part I: Items suggested for discussion with the press and public present

1 Appointment of Chair

To appoint a Chair for the meeting.

2 Declarations of Interest

Councillors are reminded of the need to declare any disclosable pecuniary interests that relate to business on the agenda and which have not already been included in the register of interests, before any discussion takes place on the item. Unless the interest is sensitive, you must also disclose the nature of the interest. In accordance with the Council's Code of Conduct, you must then leave the room and must not participate in any further discussion of the item. Councillors requiring clarification should seek the advice of the Monitoring Officer prior to the day of the meeting.

3 LOCAL GOVERNMENT (ACCESS TO INFORMATION) ACT 1985 EXCLUSION OF PRESS AND PUBLIC

To pass the following resolution:

RESOLVED that, under Section 100A (4) of the Local Government Act 1972, the press and public be excluded from the meeting for items 6 and 7 on the grounds that it involves the likely disclosure of exempt information as defined in paragraphs 1 and 2 of Part I of Schedule 12A of the Act.

LOCAL GOVERNMENT (MISCELLANEOUS PROVISIONS) ACT 1976

TOWN POLICE CLAUSES ACT 1847

- 4 **Application to renew private hire vehicle licence over 9 years old**
To consider the report of the Environmental Health and Licensing Manager. (Pages 3 - 14)
- 5 **Application to renew private hire vehicle licence over 10 years old**
To consider the report of the Environmental Health and Licensing Manager. (Pages 15 - 34)

Part II: Item suggested for discussion with the press and public excluded

- 6 **Application for the GRANT of a Hackney Carriage / Private Hire drivers licence. To determine if the Applicant is fit and proper**
To consider the report of the Environmental Health and Licensing Manager. (Pages 35 - 44)
- 7 **Application for the GRANT of a Hackney Carriage / Private Hire drivers licence. To determine if the Applicant is fit and proper**
To consider the report of the Environmental Health and Licensing Manager. (Pages 45 - 54)

Individual reports on this agenda can be produced in large print on request to Democratic Services (Committees) on 01392 265107.

REPORT TO LICENSING (SUB) COMMITTEE

Time and Date of Hearing: 24 NOVEMBER 2017 PART 1 Matter

Report of: Environmental Health and Licensing Manager

Type of Application: RENEWAL of a licence relating to a Private Hire vehicle over 9 years old.

Legislation: Local Government (Miscellaneous Provisions) Act 1976

Town Police Clauses Act 1847

Ward Application Refers to:

Not Applicable

Applicant: Mr Abir ALI

Premises Address: Not Applicable

1. What is the report about?

- 1.1 An application has been received from Mr Abir Ali, a licensed taxi driver seeking permission for the renewal of a private hire vehicle licence for a vehicle which is over 9 years old at the renewal date. This is a matter that cannot be dealt with under delegated powers.

2. Are there any representations?

- 2.1 There is no provision in the legislation for anyone to submit representations relating to this kind of application.

3. Report details:

- 3.1 The vehicle is a Toyota Prius registration N7 LEK. The vehicle has been licensed as a private hire vehicle since 2010 and the date of the vehicle's registration is 20 December 2007 making the vehicle over 9 years old at the renewal date. The existing policy in place regarding the renewal of private hire vehicles over 9 years old can be found at Appendix M Private Hire Licensing – Vehicle Specifications, M4, extracted from (*Practices and Procedures for the control of Hackney Carriage and Private Hire Vehicles, Drivers and Operators*) November 2016. *Exeter City Council*.

I would draw your attention to the following extract from the policy.

‘Vehicles presented for renewal that are between 9 and 10 years old will be referred to the licensing sub-committee for determination. Such applications should be submitted at least 4 weeks prior to the expiry date on the licence, as it may take several weeks to convene a licensing sub-committee. Applicants will be advised to provide a comprehensive report into the mechanical fitness of the vehicle as outlined above’.

- 3.2 The recorded mileage of the vehicle at the time of the last MOT on 10 November 2017 was 256834 miles. You will see from the MOT certificate that there are 4 advisories. The MOT is attached as a supporting document. The vehicle was inspected by an independent vehicle inspector on 10 November 2017 and the report is attached as a supporting document. The vehicle was inspected by a Licensing Officer on 13 November 2017 and the vehicle appeared to be in a very good condition. Photographs are attached of the bodywork and the interior of the vehicle as supporting documents.

4. What are the legal aspects?

4.1

Section 48(1) of the Local Government (Miscellaneous Provisions) Act 1976 ('the Act') states that a district council may on receipt of an application from the proprietor of any vehicle for the grant in respect of such vehicle of a licence to use the vehicle as a private hire vehicle, grant in respect thereof a vehicle licence:

Provided that a district council shall not grant such a licence unless they are satisfied-

a) that the vehicle is-

- i) suitable in type, size and design for use as a private hire vehicle;
- ii) not of such design and appearance as to lead any person to believe that the vehicle is a hackney carriage;
- iii) in a suitable mechanical condition;
- iv) safe; and
- v) comfortable;

b) that there is in force in relation to the use of the vehicle a policy of insurance or such security as complies with the requirements of Part VI of the Road Traffic Act 1988,

and shall not refuse such a licence for the purpose of limiting the number of vehicles in respect of which such licence are granted by the council.

4.2 Under Section 48(4)(c) of the Act the Licensing Sub-Committee may grant a licence for a maximum period of 12 months.

4.3 Any person aggrieved by a refusal of the Licensing Sub-Committee to grant a vehicle licence under Section 48 of the Act may appeal to the Magistrates Court within 21 days of receiving written notice of the refusal.

5. Recommendations:

5.1 The Licensing Sub-Committee are asked to determine the application having regard to current policy.

Environmental Health and Licensing Manager

Local Government (Access to Information) Act 1972 (as amended)

Background papers used in compiling this report:-

None

Contact for enquires:
Democratic Services (Committees)
Room 2.3
01392 265275

N.B THIS IS NOT PART OF THE REPORT

LOCAL GOVERNMENT (MISCELLANEOUS PROVISIONS) ACT 1976

HACKNEY CARRIAGE AND PRIVATE HIRE VEHICLE / DRIVERS LICENCES

You are invited to appear before the Licensing Sub-Committee to speak in support of your application. A legal or other adviser may accompany you but may not appear instead of you.

Your Application

Depending on the circumstances, your application may be heard in part two of the Committee meeting procedures from which members of the public and press are excluded. You will be notified in advance if your application will be a part two matter, if you have not been advised of this, the hearing will be in the Public domain.

You or your adviser would be expected to respond to an officer's verbal introduction outlining the above report. You or your adviser may be asked questions and may be invited to ask questions if appropriate.

At the end of the hearing you will be asked to withdraw and the Committee will reach a decision. On conclusion of the decision making process you will then be recalled and the decision will be announced.



Driver & Vehicle
Standards
Agency

MOT Test Certificate

MOT Test Number 190364200440	Vehicle Registration Mark N7LEK	Vehicle Identification Number JTDKB20U603336140
Make TOYOTA	Model PRIUS	Colour Silver
Issuer's Name S. C. LEWIS	Test Class 4	Country of Registration Great Britain
Expiry Date 10 November 2018 (EIGHTEEN)	Issued 10 Nov 2017	Test Station V108653

Odometer Reading and History

10 11 2017:	256834 mi
15 11 2016:	210021 mi
26 10 2015:	185865 mi
14 11 2014:	162709 mi

Inspection Authority

SOWTON TYRES & MOT LTD
UNIT 4
KESTREL WAY
SOWTON INDUSTRIAL ESTATE
EXETER
EX2 7JS
01392 365511

Additional Information

To preserve the anniversary of the expiry date, the earliest you can present your vehicle for test is 20 October 2018.

Signature of issuer



Advisory Information

001 (Both front headlight units cloudy)
002 Registration plate deteriorated but not likely to be misread Front [6.3.1d]
003 Trailing arm has slight play in a pin/bush (Both rear) [2.4.G.2]
004 (EML light indicates a fault)

About this document

This document is a receipt style certificate telling you that an MOT Test pass result has been recorded in the Driver & Vehicle Standards Agency's (DVSA's) database of MOT Test results; this can be verified at www.gov.uk/check-mot-status. This test certificate relates only to the condition of the components examined at the time of test. It does not confirm the vehicle will remain fit for use throughout the validity period of the certificate. Please check carefully that the details are correct. The first advisory items listed above do not constitute MOT failure items, they are drawn to your attention for advice. For further information about this document, please visit www.gov.uk/getting-an-mot or contact DVSA on 0300 123 9000*. This call may be monitored or recorded for lawful purposes.

PAID £45.00 IN FULL

BCS Check Sheet



Job Ref: 200440

Details

Name	ABIR ALI	Reg No.	N7 LEK.		
Telephone	07427 664 965.	Vehicle	TOYOTA PRIUS.	Service book stamped	y/n
Date	10/11/2017	Mileage	256839	Service light reset	y/n
	Visually OK	Date of next MOT	19/11/2018	Vehicle washed & vacuumed	y/n
	Advisory				
	Needs urgent attention				

Service

Type of service completed: Full inspection (TAXI)

Around the vehicle	Green	Yellow	Red	Report	Suggested action
Horn	/				
Wipers	/				
Washers	/				
Instruments	/				
Brake lights	/				
Indicators	/				
Reversing lights	/				
Fog lights	/				
Headlights		/			PLASTIC LENS (LOUDING UP)
Number plate lights	/				FRONT NO PLATE (DETERIORATED)

Under the bonnet	Green	Yellow	Red	Report	Suggested action
Brake fluid level	/				
Coolant level	/				
Engine oil level	/				
Fan belt	/				

Raise vehicle

	Depth mm							
	Green	Yellow	Red	Outer	Middle	Inner	Pressure	Condition
Near side								
Front tyre	/			6	8	7	34	9001
Rear tyre	/			7	8	7	32	9001
Off side								
Front tyre	/			7	8	7	34	9001
Rear tyre	/			7	8	7	32	9001
Boot / tailgate								
Check spare tyre	/			/	/	/	/	/

Under the vehicle	Green	Yellow	Red	Report	Suggested action
Pads / discs	/				

Details of all work completed and Technician observations

EML LIGHT ON.
 BOTH REAR TRAILING AXLES HAVE SHSHT
 PLAY FORMING IN PIN/SUSP.

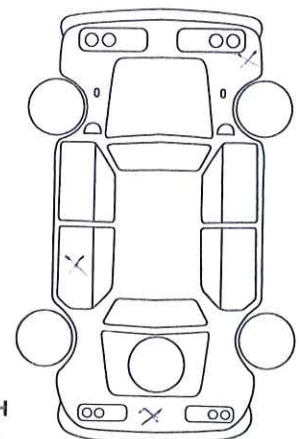

X = SCRATCH
 O = DAMAGE

Technician Signature

[Handwritten Signature]

Date 10/11/2017



13.11.2017 12:38

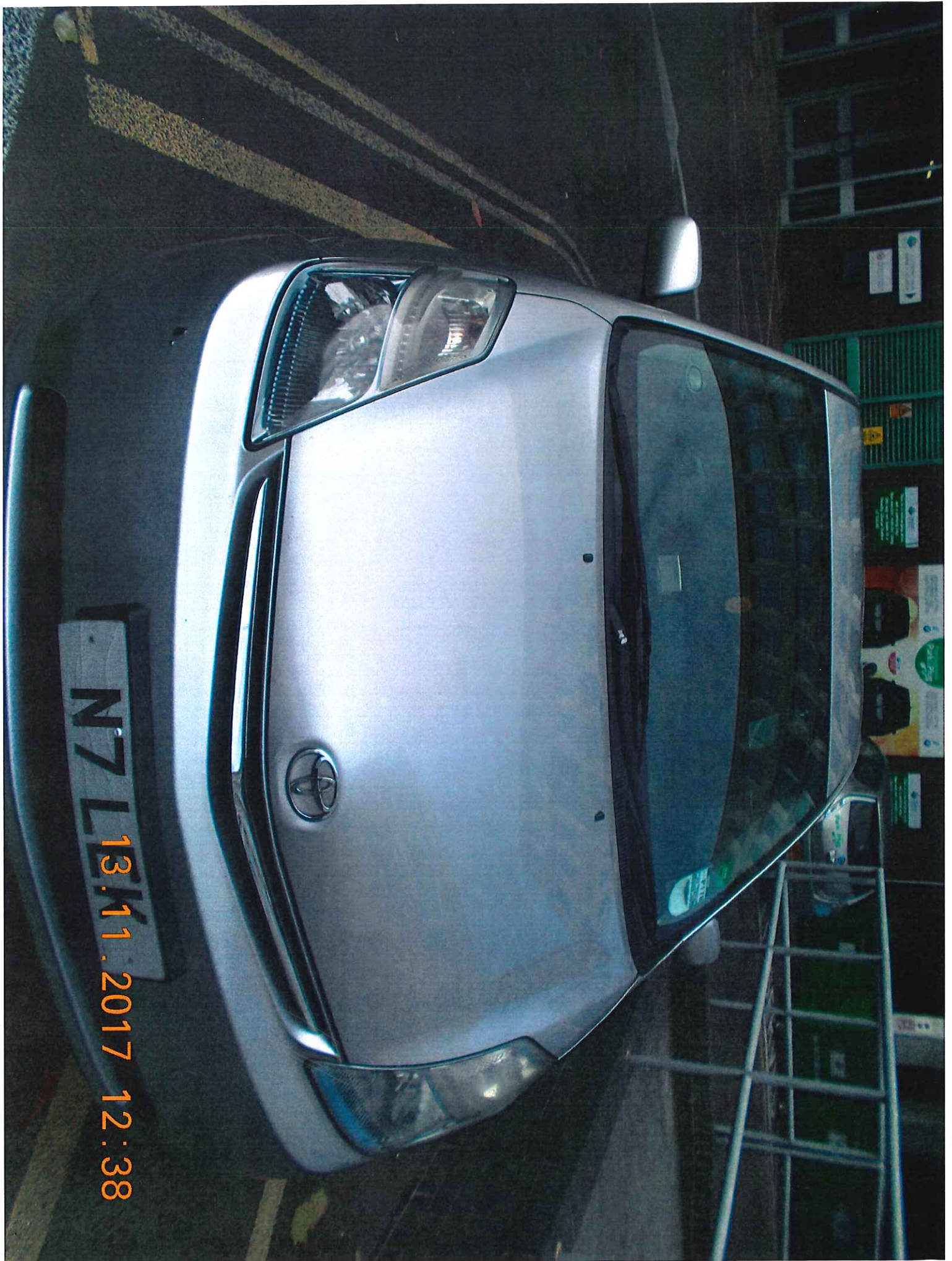



13.11.2017 12:38



13.11.2017 12:39

13.11.2017 12:38

This page is intentionally left blank

REPORT TO LICENSING (SUB) COMMITTEE

Time and Date of Hearing: 24 NOVEMBER 2017 PART 1 Matter

Report of: Environmental Health and Licensing Manager

Type of Application: RENEWAL of a licence relating to a Private Hire vehicle over 10 years old.

Legislation: Local Government (Miscellaneous Provisions) Act 1976
Town Police Clauses Act 1847

Applicant: Mr Ron HOOKER

1. What is the report about?

- 1.1 An application has been received from Mr Ron Hooker, a licensed taxi driver seeking permission for the renewal of a private hire vehicle licence for a vehicle which is over 10 years old at the renewal date. This is a matter that cannot be dealt with under delegated powers.

2. Are there any representations?

- 2.1 There is no provision in the legislation for anyone to submit representations relating to this kind of application.

3. Report details:

- 3.1 The vehicle is a Ford Galaxy registration EA07 FXB. The vehicle has been licensed as a private hire vehicle since 2008 and the date of the vehicle's registration is 18 April 2007 making the vehicle over 10 years old at the renewal date. The policy in place for the renewal of private hire vehicles over 10 years old is the Practices and Procedures for the control of Hackney Carriage and Private Hire Vehicles, Drivers and Operators. Appendix M Private Hire Licensing – Vehicle Specifications, M4 states;

‘Vehicles presented for renewal that are more 10 years old, shall not be granted. However the applicant will be given the right to apply for the application to be considered by a licensing sub-committee if they feel that their particular circumstances justify a deviation from the existing Policies.’

- 3.2 The recorded mileage of the vehicle at the time of the last MOT on 7 November 2017 was 244523 miles. You will see from the MOT certificate that there are no advisories. The MOT is attached as a supporting document. The vehicle was inspected by an independent vehicle inspector on 7 November 2017 and the report is attached as a supporting document. The vehicle was inspected by a Licensing Officer on 13 November 2017 and the vehicle appeared to be in a very good condition. Photographs are attached of the bodywork and the interior of the vehicle as supporting documents.

4. What are the legal aspects?

- 4.1 Section 48(1) of the Local Government (Miscellaneous Provisions) Act 1976 ('the Act') states that a district council may on receipt of an application from the proprietor of any vehicle for the grant in respect of such vehicle of a licence to use the vehicle as a private hire vehicle, grant in respect thereof a vehicle licence:

Provided that a district council shall not grant such a licence unless they are satisfied-

a) that the vehicle is-

- i) suitable in type, size and design for use as a private hire vehicle;
- ii) not of such design and appearance as to lead any person to believe that the vehicle is a hackney carriage;
- iii) in a suitable mechanical condition;
- iv) safe; and
- v) comfortable;

b) that there is in force in relation to the use of the vehicle a policy of insurance or such security as complies with the requirements of Part VI of the Road Traffic Act 1988,

and shall not refuse such a licence for the purpose of limiting the number of vehicles in respect of which such licence are granted by the council.

- 4.2 Under Section 48(4)(c) of the Act the Licensing Sub-Committee may grant a licence for a maximum period of 12 months.
- 4.3 Any person aggrieved by a refusal of the Licensing Sub-Committee to grant a vehicle licence under Section 48 of the Act may appeal to the Magistrates Court within 21 days of receiving written notice of the refusal.

5. Recommendations:

- 5.1 The Licensing Sub-Committee are asked to determine the application having regard to current policy.

Environmental Health and Licensing Manager

Local Government (Access to Information) Act 1972 (as amended)

Background papers used in compiling this report:-

None

Contact for enquires:
Democratic Services (Committees)
Room 2.3
01392 265275

N.B THIS IS NOT PART OF THE REPORT

LOCAL GOVERNMENT (MISCELLANEOUS PROVISIONS) ACT 1976

HACKNEY CARRIAGE AND PRIVATE HIRE VEHICLE / DRIVERS LICENCES

You are invited to appear before the Licensing Sub-Committee to speak in support of your application. A legal or other adviser may accompany you but may not appear instead of you.

Your Application

Depending on the circumstances, your application may be heard in part two of the Committee meeting procedures from which members of the public and press are excluded. You will be notified in advance if your application will be a part two matter, if you have not been advised of this, the hearing will be in the Public domain.

You or your adviser would be expected to respond to an officer's verbal introduction outlining the above report. You or your adviser may be asked questions and may be invited to ask questions if appropriate.

At the end of the hearing you will be asked to withdraw and the Committee will reach a decision. On conclusion of the decision making process you will then be recalled and the decision will be announced.

This page is intentionally left blank



MOT Test Number

265326515405

Vehicle Registration Mark

EA07FXB

Vehicle Identification Number

WF0MXXGBWM7D55850

Make

FORD

Model

GALAXY

Colour

Silver

Issuer's Name

C. FONE

Test Class

4

Country of Registration

Great Britain

Expiry Date

9 November 2018 (EIGHTEEN)

Issued

7 Nov 2017

Test Station

1744BH

Odometer Reading and History

7 11 2017: 244523 mi
26 10 2016: 225128 mi
28 10 2015: 211186 mi
10 11 2014: Unreadable

Inspection Authority

FIRST CALL MOT CENTRE
UNIT 6
CITY INDUSTRIAL ESTATE
HAVEN ROAD
EXETER
EX2 8DD
01392499866

Additional Information

To preserve the anniversary of the expiry date, the earliest you can present your vehicle for test is 10 October 2018.

Signature of Issuer

C. Fone

Advisory Information

About this document

- 1 This document is a receipt style certificate telling you that an MOT Test pass result has been recorded in the Driver & Vehicle Standards Agency's (DVSA's) database of MOT Test results; this can be verified at www.gov.uk/check-mot-status.
 - 2 A test certificate relates only to the condition of the components examined at the time of test. It does not confirm the vehicle will remain roadworthy throughout the validity period of the certificate.
 - 3 Check carefully that the details are correct.
 - 4 Whilst advisory items listed above do not constitute MOT failure items, they are drawn to your attention for advice.
 - 5 For further information about this document, please visit www.gov.uk/getting-an-mot or contact DVSA on 0300 123 9000*.
- *Your call may be monitored or recorded for lawful purposes.

Comprehensive Vehicle Inspection Report

Customer Details

Exeter Motor Works
Unit 1 City Industrial Estate
Michael Browning Way
Exeter
Devon EX2 8DD

Report Date: 07/11/17

Report No: 10558

Customer's contact details

Home:

Work: 01392 464643

Mobile: 07810825111

VEHICLE DETAILS

Make FORD

Registration Number EA07 FXB

Model GALAXY GHIA TDCI

Colour SILVER

Vehicle Identity Number (VIN) WF0MXXGBWM7D55850

VIN Checked and confirmed
on vehicle
Yes X No

V5/Registration document
available and checked No

MOT Certificate available and
checked YES

Mileage reading In 244526
(Not guaranteed) Out 244523

MOT Expiry Date 09/11/18

Vehicle Excise Licence Expiry 01/03/18

Date of inspection 07/11/17

Time of inspection 16:00

Location of vehicle Exeter Motor Works, Unit 1 City Industrial Estate EX2 8DD

Lighting Good

Weather. Good
(See notes)

Ramp available. Yes No
(See notes)

SECURITY CHECK

The vehicle identification number on this vehicle was checked and found to be **consistent** with the manufacturer's format.

SUMMARY REPORT

READY FOR USE – No faults found, suitable for immediate use.

ADVISABLE REPAIRS ONLY – Suitable for immediate use but advisable repairs should be planned for.

ESSENTIAL AND ADVISABLE REPAIRS REQUIRED – Not suitable unless all essential repairs are undertaken and advisable repairs, if any are planned for.

UNSATISFACTORY – Vehicle has significant deficiencies, which are judged to be impractical or uneconomical to repair to a satisfactory standard.

Please read all pages of this report

KEY:

- S satisfactory
- R repainted
- = scratch
- X dent
- O corrosion
- C chip / rust
- P previous repairs

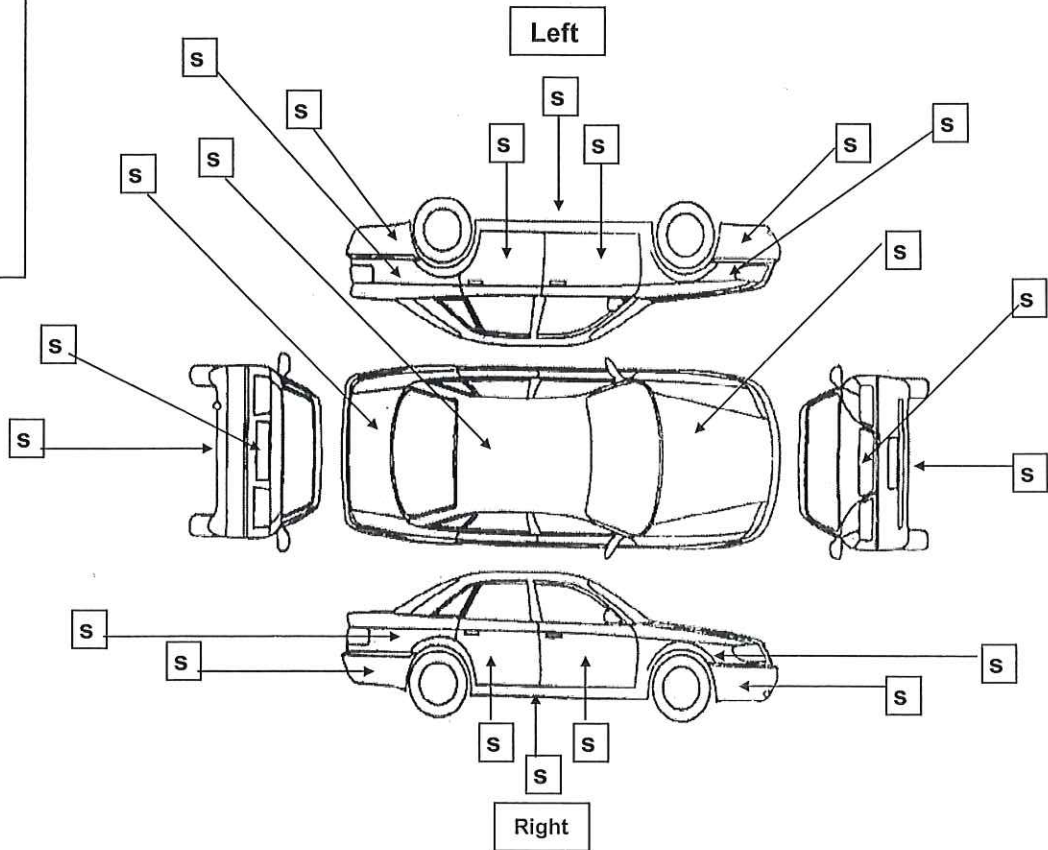

Minor blemishes, which are acceptable fair wear and tear for the vehicle's age, recorded mileage and type, are not recorded and you should satisfy yourself in this regard.

EVIDENCE OF BODYWORK REPAIRS Yes X No
BODYWORK CLEAN AND DRY Yes X No (See Notes)

Comments

The exterior body condition was good and commensurate with the vehicles age and recorded mileage.

KEY FOR POINTS ON FOLLOWING PAGES

- S Satisfactory for age and recorded mileage
- Could not be checked
- x Essential repair requiring immediate attention
- A Advisable repair should be considered prior to purchase
- N/A Not applicable
- Y Yes
- N No

Please note: Right = Off side (O/S) and Left = Near side (N/S) as viewed from the driver's seat.

BODY EXTERIOR

1. Panel Condition / alignment	S	6. Door locks - operation	S	11. Mud flaps	S
2. Paintwork	S	7. Fuel filler cover and cap	S	12. Body panels	S
3. Exterior trim /grille	S	8. Soft top / Hard top (operation)	N/A	13. Bonnet catch	S
4. Glass	S	9. Body damage	S	14. Bonnet hinges	S
5. Bumpers / No plates – Ft / Rr	S	10. Corrosion	No	No	

ENGINE COMPARTMENT	PETROL	DIESEL <input checked="" type="checkbox"/>	MULTI-FUEL <input type="checkbox"/>	No. of CYLINDERS: 4	
15. Coolant Level / Condition	S	22. Power Steering – oil level	S	29. Turbo / supercharger	--
16. Coolant leaks	No	23. Clutch Fluid	S	30. Fuel pump / pipes	S
17. Antifreeze *	S	24. Brake Fluid	S	31. Accelerator linkage	S
18. Radiator / Cap	S	25. Engine Oil level	S	32. Cold starting	--
19. Hoses / Pipes	S	26. External leaks (upper engine)	S	33. Fast idle (cold)	--
20. Drive Belts	--	27. Engine mountings	S	34. Noise level (cold)	--
21. Water Pump (Not visible)	--	28. Fuel Injection	S	35. Excess fumes / smoke	No

Note - To ensure future serviceability, it is important that the engine camshaft belt is replaced at intervals specified by the manufacturer. It is in your best interests you ensure that this is carried out. * Antifreeze only has a 2/3 year life span and requires its strength adjusting after this time or replacing as per manufacturers specifications.

ELECTRICAL / CONTROLS

36. Starting system / Ignition lock	S	41. Rear lights & No. plate lights	S	49. Instruments	S
37. Battery condition	S	42. Stop lights	S	50. Horn	S
38. Battery voltages:	S	43. Indicator/ Hazard lights	S	51. Radio/Cass/CD/Aerial	S
- Normal 12.45 volts	S	44. Reverse / Fog lights	S	52. Heater / Fan controls	S
- Starting 10.22 volts	S	45. Auxiliary lights	N/A	53. Air Con operation	S
- Charging 14.84 volts	S	46. Interior / Panel lights	S	54. Windows / Sun roof	S
39. Headlights	S	47. Mirrors (electric)	S	55. Wipers / Washers	S
40. Sidelights / running lights	S	48. Controls / Switches	S	56. Headlamp wash / wipe	N/A

Note - We are unable to verify dash panel light and switch back lighting operation due to the daylight conditions. Please note that switching them "on or off" only assesses electrical components. Accuracy of instruments cannot be assessed.

INTERIOR / LUGGAGE COMPARTMENT

INTERIOR / LUGGAGE COMPARTMENT		NUMBER OF SEATS: 7	
57. Steering Wheel / Adjustment	S	64. Door seals / hinges	S
58. Seat upholstery	S	65. Interior sills	S
59. Seat adjustment	S	66. Headlining / visors	S
60. Seatbelts	S	67. Sun roof	N/A
61. Carpets / Mats	S	68. Dash panel (condition)	S
62. Door trim panels	S	69. Cigarette lighter	N/A
63. Door fittings / operation	S	70. Mirrors (internal)	S
		71. Rear parcel shelf / load cover	--
		72. Boot / tailgate lock	S
		73. Luggage area trim con	S
		74. Illumination light	S
		75. Tool kit	S
		76. Hard / Soft top (condition)	N/A
		77. Tonneau cover	N/A

FRONT SUSPENSION / STEERING / UNDER FRAME

78. Engine underside leakage	No	83. Wheel hubs / bearings	S	88. Sub-frames mountings	S
79. Steering joints/ ball joints	S	84. Springs/suspension units	S	89. Suspension arms / mountings	S
80. Steering rack / box	S	85. Pipes / hoses	S	90. Tie bars / anti roll bars	S
81. Chassis members	S	86. Dampers (condition / leaks)	S	91. Corrosion protection	Yes
82. Power steering (operation)	S	87. Gaiters	S	92. Corrosion – floor/chassis	No

REAR SUSPENSION / UNDER FRAME

93. Springs/suspension bars	S	97. Location rods/fixings	N/A	101. Sub-frames/ mountings	S
94. Anti roll bar	S	98. Bump stops/gaiters	N/A	102. Chassis members	S
95. Dampers/bushes	S	99. Wheel hubs/bearings	S	103. Corrosion protection	Yes
96. Suspension arms/fixings	N/A	100. Pipes/hoses	N/A	104. Corrosion – floor/chassis	No

CLUTCH / TRANSMISSION

CLUTCH / TRANSMISSION	MANUAL <input checked="" type="checkbox"/>	AUTOMATIC <input type="checkbox"/>	MULTI-USE / 4x4 <input type="checkbox"/>	FIVE SPEED GEARBOX	
105. Fluid / oil leaks	No	109. Casings	S	113 Backlash	S
106. Cables / adjustments	N/A	110. Mountings	S	114. Gaiters	S
107. Hydraulic system	S	111. Drive shaft assembly	S	115. Propshaft(s) / fittings	N/A
108. Linkage (wear)	S	112. Universal / sliding joints	S	116. Bearings / supports	N/A

EXHAUST SYSTEM					
117. Manifold	S	120. Silencer(s)	S	123. System condition	S
118. Pipes	S	121. Heat shields / mountings	S		
119. Catalytic converter (s)	S	122. Joints / couplings	S		

FUEL SYSTEM					
124. Tank	S	126. Fuel lines	S	128. Evidence of leaks	No
125. Tank fixings	S	127. Breather pipes	S		

BRAKES					
129. Master cylinder security	S	132. Flexible hoses	S	135. Handbrake op / adjustment	S
130. Fluid leaks	No	133. Pipes / connections	S	136. Handbrake mechanism	S
131. Servo / power system	S	134. Discs / pads (if visible)	S	137. Pedal and pad / linkage	S

Note - If the vehicle is fitted with brake drums the internal parts including linings are not visible. Brake fluid should be replaced at the manufacturers specified intervals.

WHEELS AND TYRES Type: Alloy					
It is recommended tyres be replaced when the tread depth reaches 2mm. If uneven tyre wear is noted, this may indicate incorrect geometry, which can result in excessive and rapid tyre wear. A full steering and geometry check is recommended.					
138. Wheel Rims	S				
139. Wheel Trims	S				
Tyres	Make	Size	Type / Construction	Min tread depth	
140. Front RH	Mazzini	215/60/16	Radial	7.9mm	S
141. Front LH	Mazzini	215/60/16	Radial	7.9mm	S
142. Rear LH	Goodyear	215/60/16	Radial	7.2mm	S
143. Rear RH	Mazzini	215/60/16	Radial	7.9mm	S
144. Spare	None				A

145. ROAD TEST					
The road test has been undertaken within the speed limits and prevailing traffic conditions in the locality of the inspection. If a road test has not been carried out, please refer to the engineer's comments page.					
*If the vehicle is fitted with 4wd transmission then the systems have been checked for security, leakage and excessive noise. However, within the limitations of the road test the full functionality could not be checked.					
Test Distance	3 Miles	Speed achieved up to 40 MPH			
146. Final drive operation / Noise level	S	153. Instrument /controls function	No	160. Road holding / stability	S
147. Gearbox operation / Noise level	S	154. Steering wheel alignment	S	161. General steering / handling	S
148. Engine performance	S	155. 4WD operation *	N/A	162. Footbrake operation	S
149. Engine noise	S	156. Clutch operation **	S	163. Hand/park brake operation	S
150. Excess smoke	No	157. Cooling fan operation	S	164. Suspension noise	No
151. Overheating evidence	No	158. Steering effort	S	165. Warning lights	S
152. Auto changes / kick-down	N/A	159. Hot restarting	S	166. Cruise control	S

** It should be carefully noted that the life expectancy of clutches is uncertain and difficult to predict, being dependant on owners driving style, vehicle operation and terrain. The fact that the clutch has not been identified as faulty/slipping/juddering/noisy on the report does not and should no be taken to imply that the clutch assembly will have a continuing life expectancy from the time of our check. They can begin to slip at any time.

FINAL CHECK					
167. Oil leaks	No	168. Coolant leaks	No	169. Uneven tyre wear	No

Report No: 10558

Vehicle documents and Inspection environment notes.

Engineer Indicate with "X" as applicable.

Registration Document (V5):

- No registration document was seen with the vehicle and you are advised to satisfy yourself that the vehicle identification number and engine number (where quoted) correspond to those shown on this report. Warning: **DO NOT BUY ANY VEHICLE WITHOUT A V5.**
- The V5/Registration Document shows _____ previous keeper(s), the last change of Keeper on _____.

Security:

- The Master Key was not available. Please ensure this is supplied if the vehicle is purchased.
- The engineer recommends that relevant spare and service keys be obtained prior to purchase.
- Obtain hand books and radio codes for vehicle prior to purchase as these were not seen in the vehicle.

MOT:

- As only a small amount of time is left on the MOT Certificate (less than 3 months) the engineer recommends a full year's MOT be obtained prior to purchase.
- A Full Year MOT Certificate has been seen with the vehicle.

Servicing:

- The service history seen, indicated that the last recorded service was carried out at _____ miles. No immediate servicing is necessary. Next service is due as per manufacturer's recommendations or as per the Vehicles Service indicator.
- The service history seen, indicated that the last recorded service was carried out on the _____ at _____ miles. Therefore the engineer would suggest a full service and brake inspection to the manufacturer recommendations prior to purchase, which may reveal further defects not apparent at this examination.
- No service documentation seen with this vehicle and therefore the engineer would recommend a full service and brake inspection to the manufacturer's recommendations prior to purchase, which may reveal further defects not apparent at this examination.

Inspection conditions notes:

- No vehicle hoist/ramp was available. A large trolley jack and stands were used in order to carry out underside checks. This limits the view of the underside. Some areas could not be fully seen. There *may* be further defects, which may be visible given clear access and view.
- The body/paintwork was wet/dirty/dusty this severely restricts inspection of the paintwork. Please note that there may be other defects present, which were not visible due to the obscured paintwork, but which may become visible once dry and clean.

Report No: 10558

Engineers Comments

The vehicle is considered overall to be a fair and reasonable example of the type, being in a generally reasonable condition and generally considered to be consistent with the type for the age and indicated recorded mileage in most areas.

The items listed as "could not be checked" (---) normally indicate items were obscured by covers/shields or other equipment.

The Water pump – Engine drive belt/chain - these items could not been fully examined, as covers, trims and other equipment obscure them.

The cooling system was pressure tested to 0.7 bars, no pressure loss was noted on the system or pressure cap. The antifreeze concentration was an acceptable, but has deteriorated from its original strength and at the next routine service may need to be refreshed/replaced. It is advised that the coolant strength be checked again at the next routine service. Antifreeze only has a 2/3-year life and requires its strength adjusting after this time or replacing as per manufacturer's specifications.

The vehicle is fitted with vented front brake disc and pads, supported at the rear by a single arrangement. Although the visible brakes only show some signs of general serviceable wear, some deterioration is noted, which will need attention in the near future. It is strongly advised to remove all road wheels and examine the inner brake components, which are obscured on this vehicle prior to purchase, replacing any worn or badly corroded parts. It is probable that the front brakes at least, will need to be replaced at the next routine service.

The braking system's fluid contains the presence of some water/condensation in the system. It is recommended that the fluid content is completely replaced at the next service interval.

The steering & suspension has been assessed to MOT standard. This allows for a degree of wear and deterioration of components without rendering them unserviceable. The extent of wear is not considered excessive at this juncture and unlikely to attract MOT failure.

The road test distance and or top speed was limited due to the general area/inspection location, and/or traffic levels and/or adverse weather conditions and/or lack of fuel when the vehicle was tested and driven. Comment cannot be made in these instances in relation to possible "high speed" or "sustained speed," related driving defects, which may become apparent at a later stage after any purchase due to these limiting conditions.

Advisable Repairs

Please note that the advisable items may prove costly to repair, and must be considered.

Item	Comment
144	No Emergency inflation Equipment or Spare Wheel Found.

Additional Comments

The engineer was unable to verify dash panel light and switch back lighting operation due to the daylight conditions. Please note that switching them "on or off" only assesses electrical components. Accuracy of instruments cannot be assessed.

Although the radio operates when switched on, the full functionality of the in-car entertainment system has not been checked. This is beyond the scope of our inspections. You should ask the vendor to fully demonstrate the systems before purchase.

Report No: 10558

PLEASE READ CAREFULLY

- You are strongly advised to discuss the findings of this report with the vendor prior to making your decision to purchase the vehicle.
- Essential repairs should be investigated and rectified prior to purchase. These may be costly.
- Advisable repairs may prove costly to repair and must be considered prior to purchase.

Engineer's Name Phillip Bailey
Qualifications BSc Hons), M.I.M.I, AAE.

This page is intentionally left blank

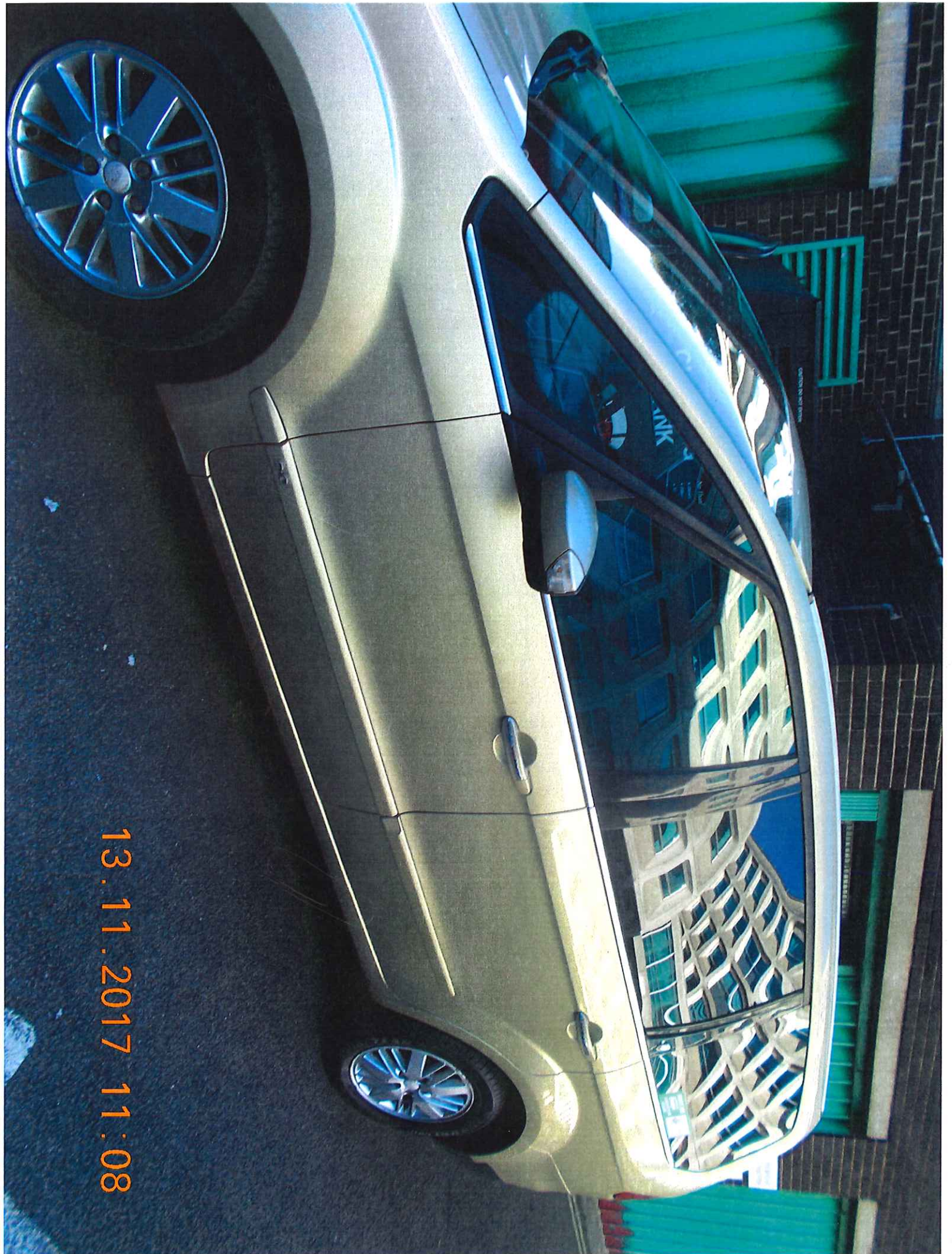

13.11.2017 11:08

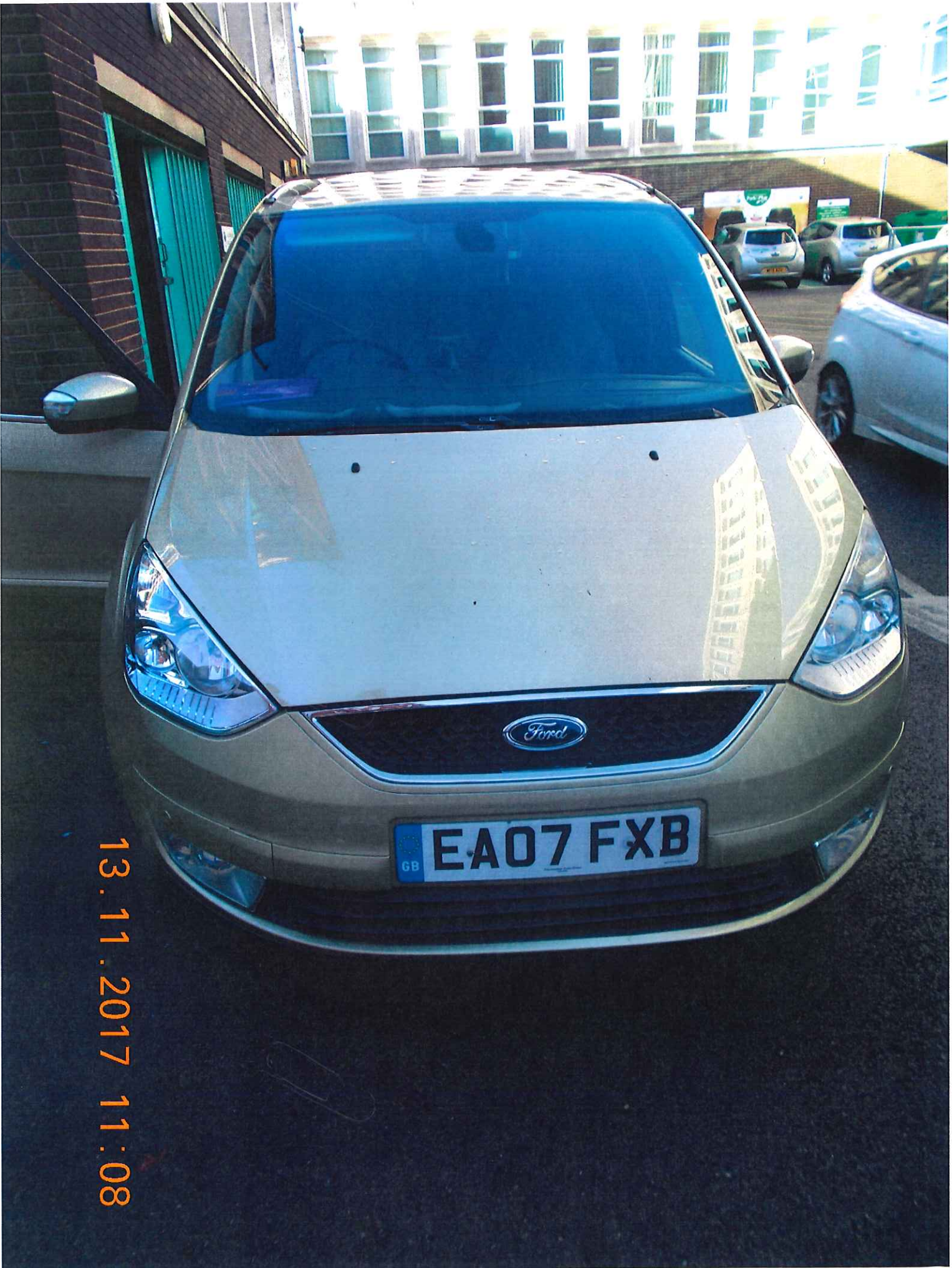

13.11.2017 11:08

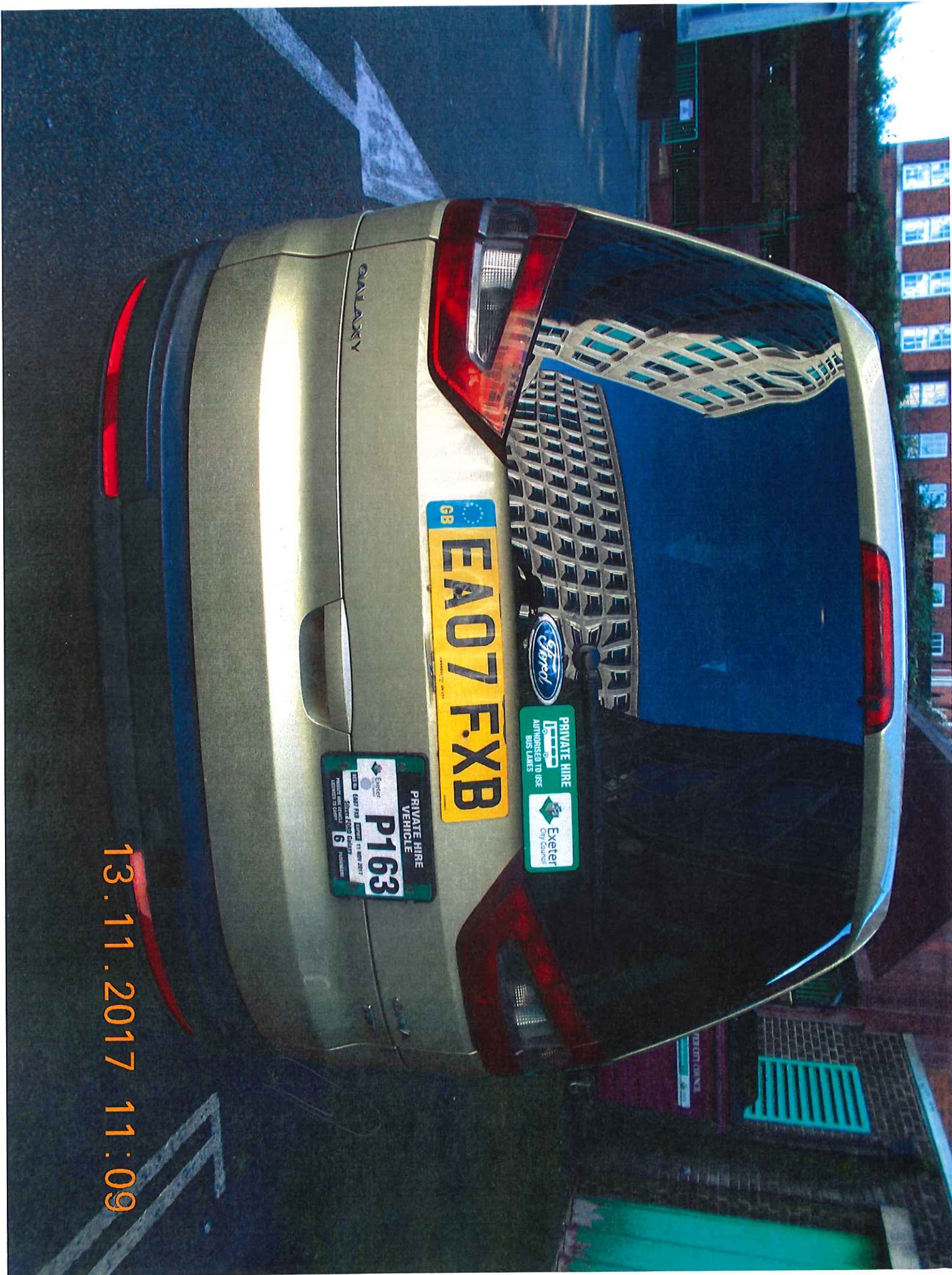

13.11.2017 11:09



13.11.2017 11:09



This page is intentionally left blank

By virtue of paragraph(s) 1, 2 of Part 1 of Schedule 12A
of the Local Government Act 1972.

Document is Restricted

This page is intentionally left blank

By virtue of paragraph(s) 1, 2 of Part 1 of Schedule 12A
of the Local Government Act 1972.

Document is Restricted

This page is intentionally left blank

By virtue of paragraph(s) 1, 2 of Part 1 of Schedule 12A
of the Local Government Act 1972.

Document is Restricted

This page is intentionally left blank

By virtue of paragraph(s) 1, 2 of Part 1 of Schedule 12A
of the Local Government Act 1972.

Document is Restricted

This page is intentionally left blank

By virtue of paragraph(s) 1, 2 of Part 1 of Schedule 12A
of the Local Government Act 1972.

Document is Restricted

This page is intentionally left blank

By virtue of paragraph(s) 1, 2 of Part 1 of Schedule 12A
of the Local Government Act 1972.

Document is Restricted

This page is intentionally left blank